

Bourns® Magnetic Components



Overview

Bourns is a top supplier of high quality magnetic components such as transformers, inductors and common mode chokes.

- Components and modules are designed to address needs for automotive, industrial, communications and consumer markets.
- Major applications include Battery Management Systems (BMS), On/Off-Board Charging, Energy Storage Systems (ESS), high-frequency Switch Mode Power Supplies, and other power conversion applications.
- Bourns® magnetic components are produced in state of the art IATF certified factories.
- Bourns® components and modules are designed for high-efficiency, compact size and excellent thermal management. They meet all major quality and safety standards.
- Bourns production facilities are equipped with best in class test, design, and production verification tools for items such as AEC-Q200 compliance and PPAP certification.



INDUSTRY STANDARDS

- UL 508, EN 61558-1, EN 60950, EN 60368-1
- Insulation Class B 125 °C, Class F 155 °C and Class H 180 °C

QUALITY

- VDA 6.3, Factory IATF 16949 certified
- High Frequency Power Topologies: Buck, Boost, SEPIC, CUK, Half and Full Bridge LLC, Push-pull, Forward, Flyback

QUALIFICATION & CERTIFICATION

- AEC-Q200
- Production Part Approval Process (PPAP)



Magnetic Components Design Capabilities

- EMI Reduction
- Design Services
- Finite Element Analysis
- Thermal Management
- Industry Standard Family Series
- Customer Driven Modified Components
- AEC-Q200 Compliance Testing Available
- SPICE Model Generation
- AC and DC Analysis
- Impedance Characterization
- Thermal Potting
- Flat Wire Windings
- Design Verification Test Facilities

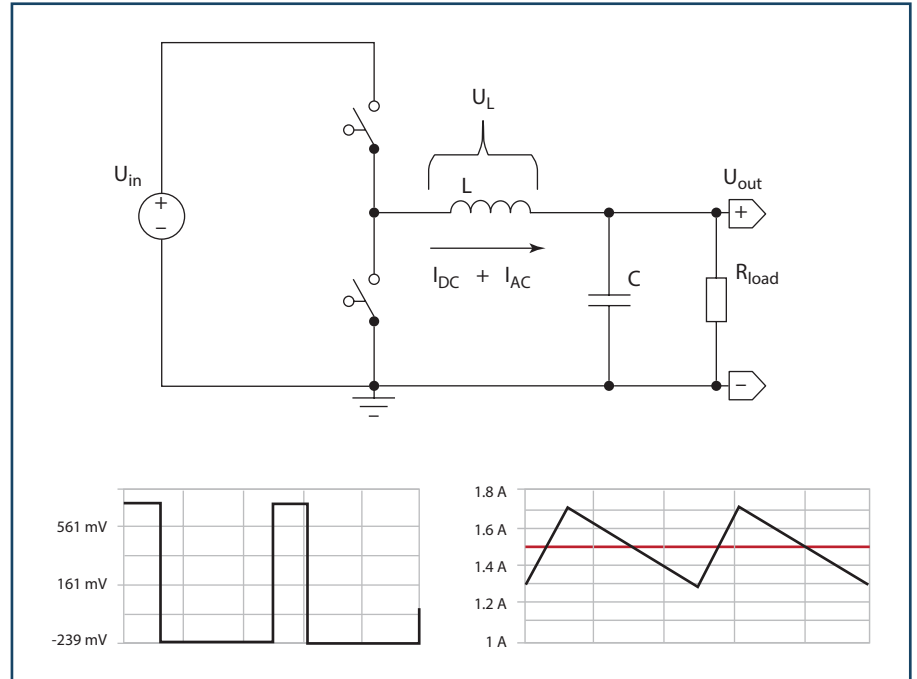

Non-Isolated AC-DC Conversion

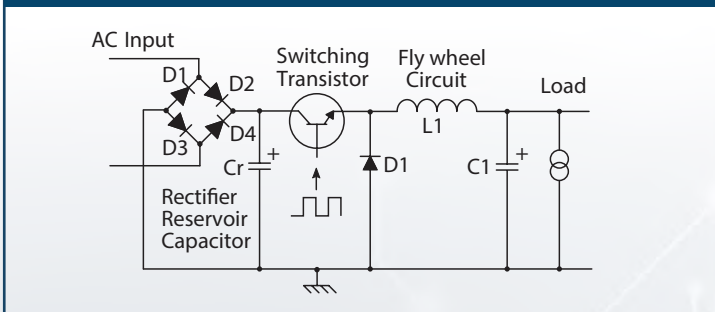

Non-Isolated DC-DC Conversion

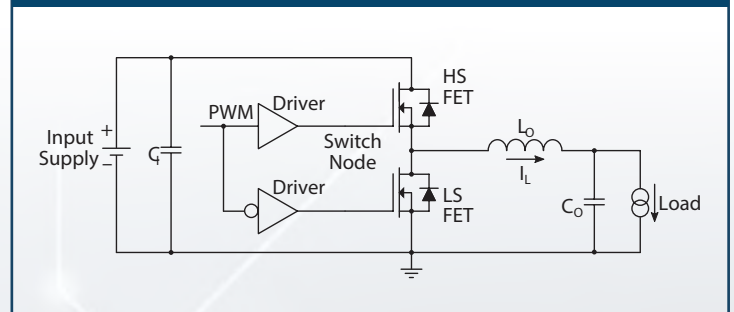

Isolated DC-DC Conversion

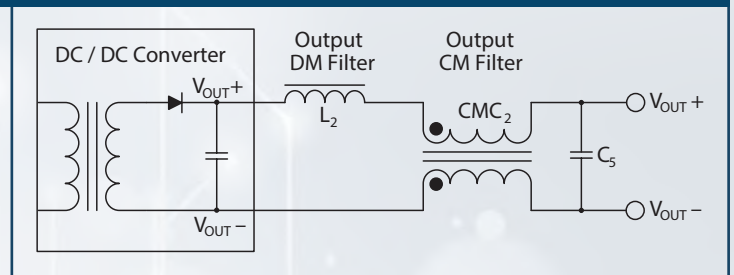
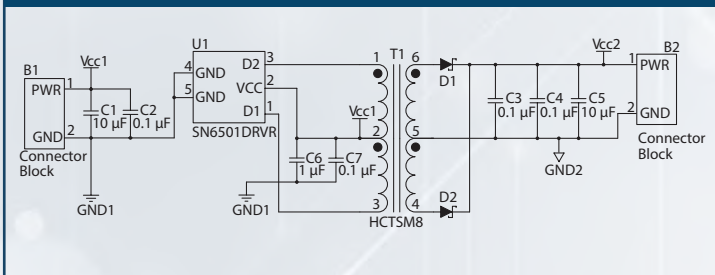

Typical CMC in EMI Signal Application

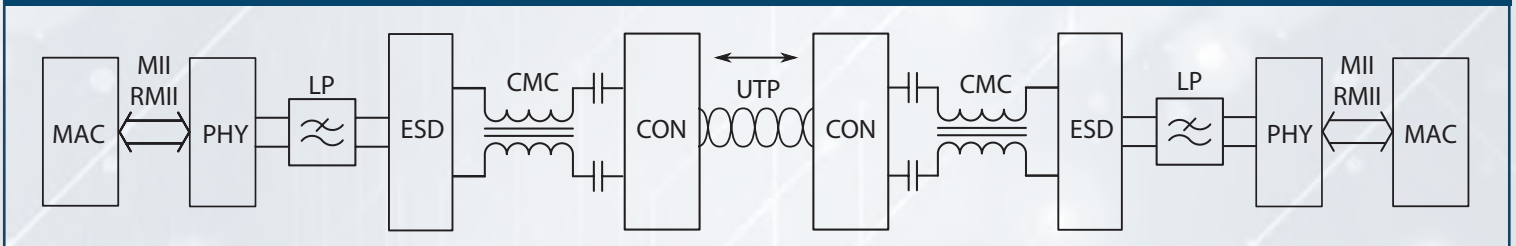

Magnetics Components

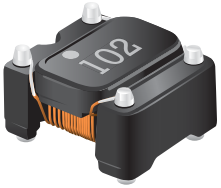

Low Power / Signal Line CMC

- Powered Line and Low Power
- Toroidal Construction
- Up to 500 mA Rated Current
- Broad Impedance Range
- CAN FD Class II and III
- -55 to +150 °C On-Board Operating Temperature
- 80 V Rated
- Low Leakage

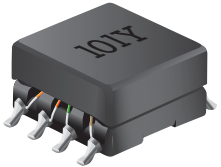

PQ2614/PQ2617HA - Choke

- Flat Wire Construction
- Low AC Resistance
- High Saturation Currents
- Low Core Loss
- SMT Leads
- Mechanical Terminals Available

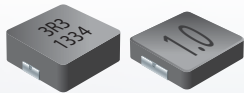

SRP - Shielded Inductor Series

- Multiple Material Mixes
 - Ferrite
 - Metal Alloy
 - Carbonyl
 - Nano-Crystalline
- High Self-Resonance Frequency
- Flat and Round Wire Versions
- AEC-Q200 Compliant
- Low Profile to 1 mm
- High Current to 70 A
- High Temperature to 180 °C
- Low Magnetostriction
- Molded Construction

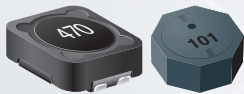

LAN Transformer

- Fully Automated Design
- Metal External Shielding
- IEEE 802.3 Compatible
- Temperature Range -40 to +85 °C
- Transformer + CMC



DC-DC SMPS

BMS Low Power Transformer

- Reinforced Insulation
- TIW and FIW Wire Construction
- >8 mm Creepage and Clearance
- 800 V Working Voltage
- 4.2 kV Dielectric Rating
- Very Low Noise Toroidal Design
- Push-Pull Operation
- AEC-Q200 Compliant
- Low Profile
- 11 Different Turns Ratios
- UL Approval
- TI SN6501/6505 Reference



Data Line / SPI

BMS Signal Transformer

- Automotive Grade
- SPI Single and Dual Channel
- Transformer + CMC
- 8 mm Creepage and Clearance
- Designed for IEC 62368
- Fully UL Recognized



SDE/SDR/SRN/SRR/SRU - Inductors

- Industry Standard Size and Shape
- Unshielded
- Semi-shielded
- Shielded DR Type Core
- Low Radiation
- Low Cost
- AEC-Q200 Compliant Models Available
- Ferrite Material



Worldwide Sales/Representative Offices



Country	Phone	Email
Americas:	+1-951-781-5500	americus@bourns.com
Brazil:	+55 11 5505 0601	americus@bourns.com
China:	+86 21 64821250	asiacus@bourns.com
Europe, Middle East, Africa:	+36 88 885 877	eurocus@bourns.com
Japan:	+81 49 269 3204	asiacus@bourns.com
Korea:	+82 70 4036 7730	asiacus@bourns.com
Singapore:	+65 6348 7227	asiacus@bourns.com
Taiwan:	+886 2 25624117	asiacus@bourns.com
Other Asia-Pacific Countries:	+886 2 25624117	asiacus@bourns.com

Technical Assistance

Region	Phone	Email
Asia-Pacific:	+886 2 25624117	techweb@bourns.com
Europe, Middle East, Africa:	+36 88 885 877	eurotech@bourns.com
Americas:	+1-951-781-5500	techweb@bourns.com

BOURNS®

www.bourns.com

Bourns® products are available through an extensive network of manufacturer's representatives, agents and distributors. To obtain technical applications assistance, a quotation, or to place an order, contact a Bourns representative in your area.

Specifications subject to change without notice. Actual performance in specific customer applications may differ due to the influence of other variables. Customers should verify actual device performance in their specific applications.